

**OPTICAL SMOKE DETECTOR** DIL SWITCH ADDRESSED

Part Number 55000-665IMC

**DEVICE RESPONSE**

**Type:** Overheating/thermal combustion  
**Response:** Very good

**Type:** Smouldering/glowing combustion  
**Response:** Good

**Type:** Flaming combustion  
**Response:** Good

**Type:** Flaming with high heat output  
**Response:** Good

**Type:** Flaming - clean burning  
**Response:** Very poor

**Optical Smoke Detector, DIL style, 55000-665IMC**

Our DIL Switch Addressed (DSA) Context Plus optical detector has a moulded self extinguishing white polycarbonate case designed to allow free entry of smoke while minimising the effects of dust contamination. Stainless steel wiper contacts connect the detector to the terminals in the mounting base. Within the case is a printed circuit board which on one side has the light proof labyrinth chamber with integral gauze surrounding the optical measuring system. The other side has the address capture, signal processing and communications electronics. An infra-red light emitting diode (IR LED) within the optical chamber is arranged at an obtuse angle to a photodiode. The photo-diode has an integral daylight-blocking filter. The IR LED emits a burst of collimated light every second. In clear air the photo-diode receives no light directly from the IR LED. When smoke enters the chamber it scatters light from the IR LED onto the photodiode in an amount related to the smoke characteristics and density. The photodiode signal is processed by the optical ASIC and passed to the A/D converter on the communications ASIC ready for transmission when the device is interrogated.

The address of the DSA Context Plus detectors is set using the DIL switch located on the underside of the device. All segments are set to 0 (ON) or 1 (OFF), using a small screwdriver or similar tool. The address should be written on the label and the rear of the detector sealed.



010u/02 0832

**Technical Data**

**Detector Part No** 55000-665IMC

**Base Part No:** 45681-200

Specifications are typical and given at 23°C and 50% relative humidity unless stated.

**Communication protocol:** Apollo XP95 pulse 5-9V

**Address range:** 1 to 126

**Detector Type:** Products of combustion (smoke) detector

**Detection Principles:** Photo-electric detection of light scattered in a forward direction by smoke particles

**Chamber Configuration:** Horizontal optical bench housing an infrared emitter and sensor arranged radially to detect scattered light

**Sensor:** Silicon PIN photo-diode

**Emitter:** GaAlAs Infra-red light emitting diode

**Sampling Frequency:** 1 second

**Supply Wiring:** Two wire supply, polarity insensitive

**Terminal Functions:**

Supply positive and negative in and out connections (polarity sensitive). Remote indicator connection to LED driver base

**Supply Voltage:** 17 to 28 Volts dc

**Quiescent Current:** 340µA

**Duration of Power-up Surge Current:** 1 second

**Maximum Power-up Time:** 4 seconds for communications (measured from application of power and protocol) 10 seconds to

exceed 10 counts 35 seconds for stable clean air value

**Storage Temp:** -30°C to +80°C

**Operating Temp:** -20°C to +60°C

**Alarm Level Analogue Value:** 55

**Clean Air Analogue Value:** 25±7 counts

**Alarm Indicator:** Red Light Emitting Diode (LED)

**Alarm LED Current:** 2mA

**Remote LED Current:** 4mA at 5V (measured across remote load)

**Type Code:** (210 43) 101 00

**Sensitivity:** Nominal threshold of 2.4% light grey smoke obscuration per metre

**Humidity (No condensation or icing):** 0% to 95% relative humidity

**Wind Speed:** Unaffected by wind

**Atmospheric Pressure:** unaffected

**Vibration, Impact & Shock:** To EN54-7:2001 CE marked.

**IP Rating:** 43

**Dimensions:** (diameter x height)

Detector: 100mm x 39mm

Detector in Base:

100mm x 47mm

**Weights:** Detector: 100g Detector in Base: 157g

**Materials:** Detector Housing: White polycarbonate V-0 rated to UL 94 Terminals: Stainless Steel

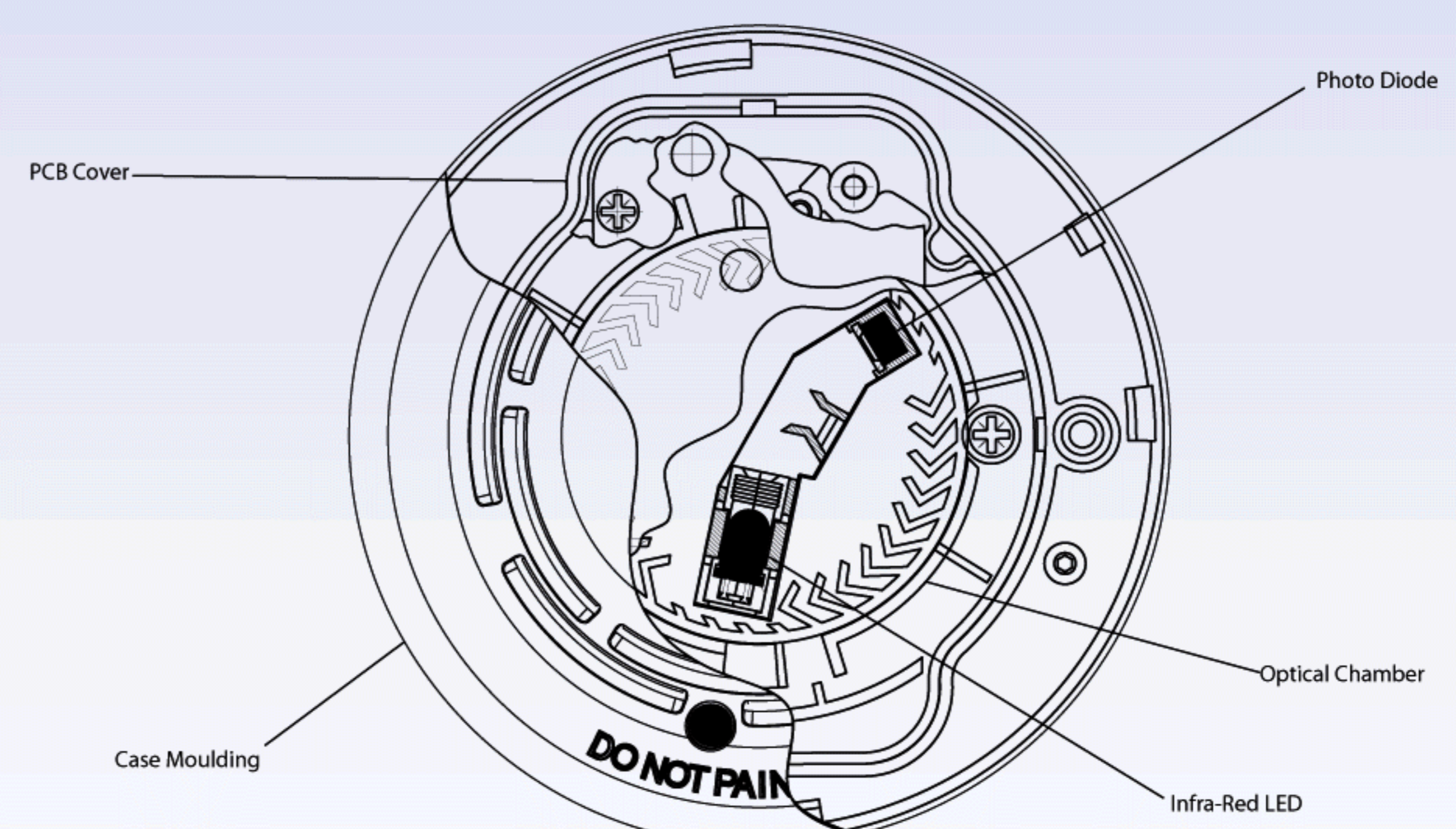

Top section view - Optical Smoke Detector